

34m HIGH SPEED FERRY

PRINCIPAL PARTICULARS

LOA:	34.67m
L(USL):	34.00m
LWL:	31.7m
BEAM:	7.5m
DRAFT:	1.73m
F.O. CAP.	15000l (nom)
F.W. CAP.	2000l (nom)
PASSENGERS:	298
ENGINES:	MTU12V2000M70 (787kW@2100rpm)
GEARBOXES:	ZF190 (2.57:1)
SPEED:	22knots (fully loaded)
SURVEY:	NSCV 1D

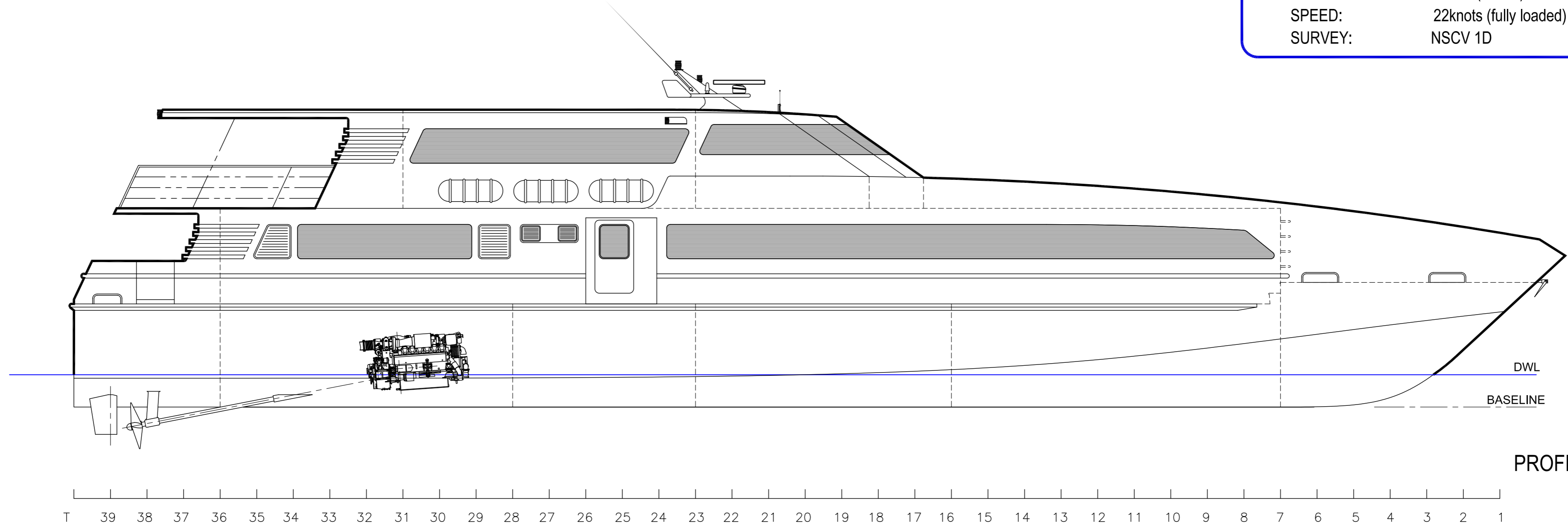

PROFILE

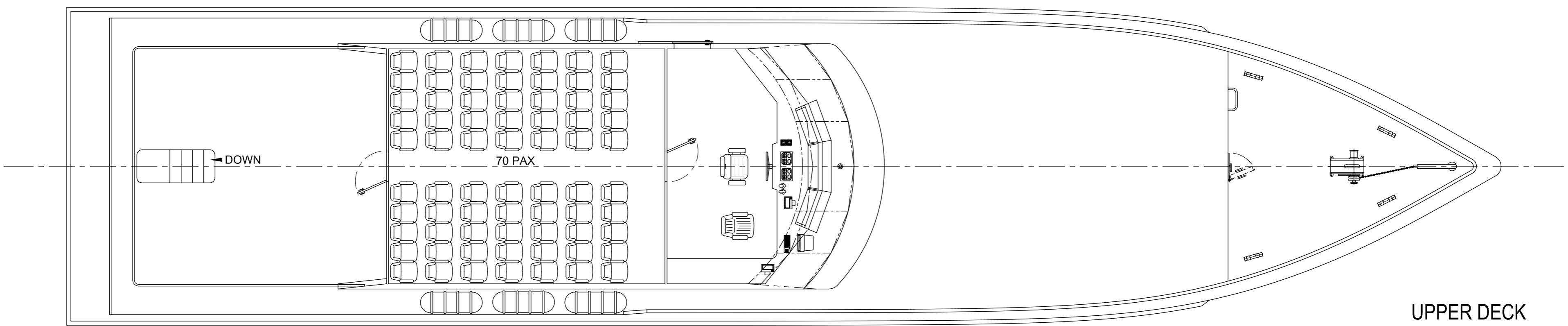

UPPER DECK

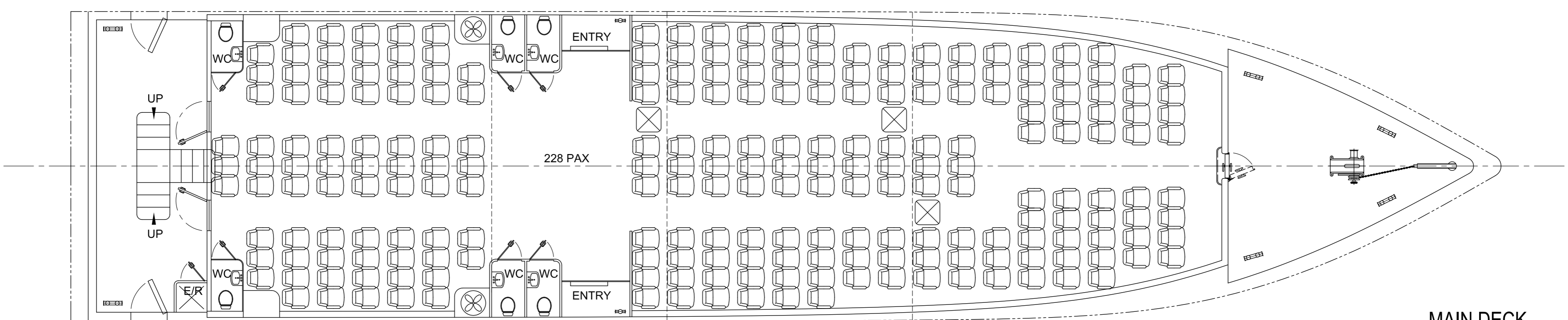

MAIN DECK

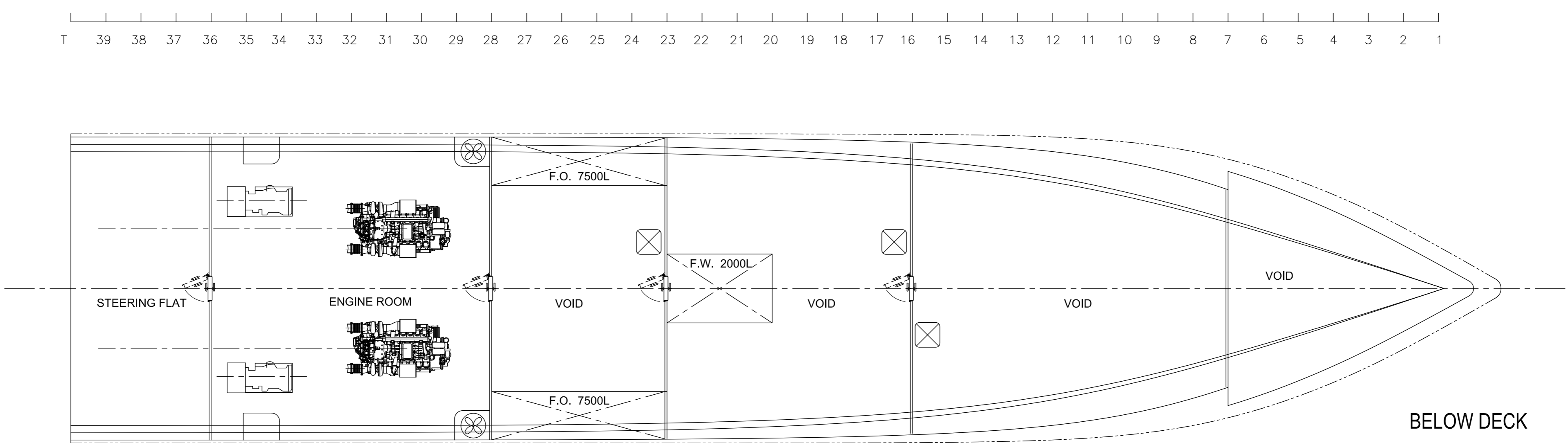

BELOW DECK